

## Fire Detectors Review and Design of an Automated Quick Responsive Fire Alarm System Based On Sms

Damini Rajurkar<sup>1</sup>, Pragati Pandey<sup>2</sup>, Sachin Sahare<sup>3</sup>, Chetan Chandekar<sup>4</sup>,  
Prof. Vipin S. Muley<sup>5</sup>

<sup>1,2,3,4</sup>Students, Tusiramji Gaikwad Patil College of Engineering and Technology Mohgaon, Nagpur.

<sup>5</sup>Assistant Professor and HOD Electrical Engineering, Tusiramji Gaikwad Patil College of Engineering and Technology Mohgaon, Nagpur.

---

### Abstract

In this work fire detector review type is used to alert any fire incidents in household or industrial purpose. The aim of the system designed is to alert the distant property owner efficiently and quickly by send the short message (SMS) via. GSM network. A linear integrated temperature sensor detects temperature beyond preset value where as semi conductor type sensor detects the presence of smoke or gas form fire hazards. The sensors are connected via. Common data line to ATmega8LAVR microcontroller. Standard GSM bands are used to send the alert messages is based on SIM300CZ GSM kit network module. The system is implementing on printed circuit board (PCB) and tested under different condition to able to evaluate its performance.

**Keywords:** Fire Detector, Microcontroller, Fire Alarm, Temperature Sensor, SMS, GSM Network.

---

### I. Introduction

To save valuable human life in emergency situation as quick as possible. So this is major need of fire detector review and design of an automated quick response fire alarm system based on SMS. This system work under quick detection. This system capable to work quick detector, alarm notification and sometimes initiation of fire extinguish. The system consists of temperature; pyro-electric sensors which can detect unfavourable accident condition with the help of processing units can alert instantly caution measures. In the emergency situation, the fire detector detects and faster alert the will yield less losses of property and humans life.

To provide the remote alarm system for the owner of the premises with the monitoring for taking the immediate actions when an emergency message is received, unlike a manual system. The system are reliable wide range of pros, they are accompanied by concerns about the being complex, incompact, non- standalone, expensive and having redundant appurtenances. Therefore, there is a necessary for the system which would be reliable, and simple as well as swift responsive, easy to implement and cost effective. Although a number of advanced system are used in project, hence it is easy to implement and cost effective automated fire alarm system is not available in developing countries.

### II. Fire Detector Review:

The fire detector review there are some different types with various features depend on different scenarios and demands. In this detector there will be more or less categorized such as heat or thermal detector, smoke or gas detector, semi conductor gas detector and flame detector.

- a) **Heat or Thermal Type Detector:** This detector is limited use. Heat or Thermal type detectors are the oldest type of autonomous fire detector, dating back to mid 1800s. Thermal type detector is very reliable, inexpensive, and easy to maintain. But these detectors are slow and by this time the detector point is predefined.
- b) **Smoke or Gas Detector:** These detectors are newer invention become widespread during 1970s and 1980s. These detectors detect the fire in early flaming and smouldering stages. These detector have some different types with different operating principle namely – optical or photoelectric detectors, ionization detector, air sample detector.
- c) **Flame Type Detector:** Flame type detector are the equipment to detect the phenomena of a flame fire. There are various type depending upon the light wavelength such as UV rays, infrared and combination of UV/ IR type detectors UV detector wavelength are generally work on shorter than 300nm. This type of

detector detects the fires and explosive situation within 3 - 4 milliseconds from the UV radiation emitted from the incident.

- d) Semi-Conductor Gas or Smoke Detector:** These semiconductor sensors are widely used in their advantageous feature. They are in small compact, inexpensive, easy to install and maintain. These detector are used to apply some metal oxide for detect the fire incident involving combustible gas, LP gas, methane, propane, alcohol, carbon monoxide etc., for their reliability. These detectors make best feature suited for our purpose and hence we opted for it in our system.

### **III. Design Of Fire Alarm System:**

The proposed fire alarm systems are placed inside the arena where multiple sensor units (each comprising smoke / gas and temperature detector) which has fire safety concerns. All the sensors are connected a data input line to the control unit. So whenever, any of the sensors detects any fault condition, the control units starts its action. The local siren are activated and GSM module. Thereby, the alarm message will be rendered at the same time through the GSM networks to the authority and the fire stations nearby.



**Fig: Overview of the system**

### **IV. Hardware Design**

In hardware system it mainly consists of sensor section, control units, network module and power supply.

- a) Sensor Section:** MQ2 is a semiconductor type sensor which senses some combustible gases like smoke, LPG, methane, propane, etc. In these sensors the sensitive material is Tin dioxide ( $\text{SnO}_2$ ). This sensitive material is come in contact with the gas to be monitored hence the electrical resistance of the sensor will be decreases, so to enable the microcontroller is respond to this situation. The analog voltage is applied to the input of the comparator IC LT1013 while the reference input voltage come in contact with variable resistor to adjust the sensing intensity. The output of the comparator is connected to the MCU via, single data line. The LED is too used to indicate to detect the smoke or gas hence the output will be higher.

The LM35 temperature sensor is a circuit sensor. Hence the output is linearly proportional to the temperature in centigrade, the sensor will be perfectly suitable for our purpose. The sensor is accurate up to  $\pm 1/4^\circ\text{C}$  at room temperature with operating range from  $-55^\circ\text{C}$  to  $150^\circ\text{C}$  and it is very low self heating as it draws the small amount of current. The output of LM35 module is analog voltage. The operation of LM35 is similar as smoke detection process. The reference voltage of this comparator is 500mV to adjust to using variable resistor same as the used in smoke sensor circuit. This module is increase it output by  $10\text{mV}/^\circ\text{C}$  at the non- inverting pin. So the temperature is greater than the preset temperature ( $50^\circ\text{C}$ ) hence the module output is high.

All the sensor units are connected to the single I/O digital pin of control units via, single data line. To protect the sensor we used the signal diode other untriggered sensor units from reverse current. The advantages of this type of connection provide the multiple sensor compatibility cover a large area, only use in single microcontroller and the necessity of multichannel ADC chip is avoided, also saving I/O pins for additional features. Any MQ2 and LM32 sensor will be trigger the data but in high state (5V) if any smoke or gas present in location, or if room temperature passes the preset value due to fire or any other accident situation.

- b) Control Units:** ATmega8L is the heart of the control units. General purpose computer is based on Atmel 8-bit AVR RISC is a low power system. Optimized power consumption, good processing speed, small physical dimension, and low cost make this microcontroller gets perfectly fit for our purpose. A Liquid Crystal Display (LCD) has been interfaced to show the status of the system to the controller. The controller operates a piezo type siren via, a 12V relay to get alert the local authority on fire hazard. RS 232 Serial Communication Protocol has been used to control the GSM module using AT commands. A DB9 serial port is connected to the microcontroller for firmware update.

**c) Network Module:** The alert message sent the location using various available network such as, wireless network (RF Tx/Rx pair), wireless sensor network, Ethernet, GSM network etc. Among these, GSM based mobile network is most sensible for the availability all over the globe and cost effectiveness. GSM module used a Subscriber Identification Module (SIM) card to operate the wireless carrier. To control the module and AT command required the process of short message which define the GSM standard. In the present work, SIM300CZ kits are used. It operates on 800/1900MHz and 900/1900MHz frequency bands. The network module operates at 5V which offers the low power consumption and reduces the cost of the system there is no communication of interface circuitry.

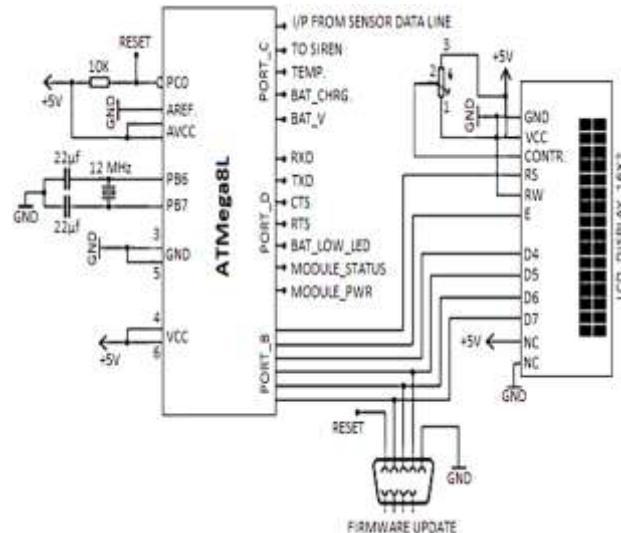
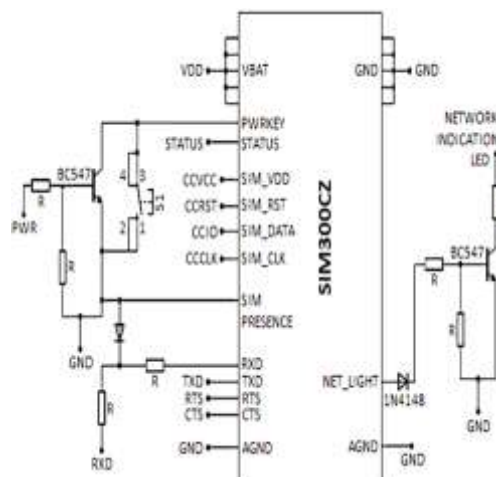

**Fig : Sensors connection scheme to the controller**

**d) Power Supply:** A 12V Li-Ion Rechargeable battery ensures to uninterrupted power supply to the entire system. A LM7805 voltage regulator which regulates the voltage at 5V to power up the microcontroller and sensor units. By using AC power the battery is charged, under the control of charger controller. By applying a reference voltage the battery charge level will be monitored to an ADC channel of the MCU. A voltage divider and zener diode are used to keep the reference voltage level between 0.5V. A red and green LED indicates the charging and battery low status of the system. If the battery voltage is less than 10.5V, if the red LED is glow, where as the battery will be charged, then the green LED is glow.

### V. Software Design

It controls the whole system by using firmware which is implemented by embedded C and built in micro compiler. Then the program is downloaded to the 8-bit ATmega8L microcontroller. It include some developing algorithm for the system, allocating memory blocks as per function, writing the separate routines for different interfacing devices and finally testing them on develop hardware.



**Fig: Circuit diagram of GSM module**

## **VI. Hardware Implementation:**

For designing two separate single layers and one double layer PCB layout by using EAGLE printed circuit board (PCB) software V.6.0 from Cad Soft computer. The single layer layouts consist of the sensor module and the double layer layout houses the control units and the network unit. All the components are placed in the PCB layout; the implemented hardware of the system is finally completed.

## **References**

- [1]. Asif, O, Hossian, Md.B, Hasan, M., Rahman, M.T. and Chowdhury, M.E.H (2014) Fire Detectors Review and Design automated, quick responsive, Fire Alarm system based on SMS.
- [2]. Zhang, L. and Wang, G. (2001) Design Implementation of automatic fire alarm system based on wireless sensor networks
- [3]. Kwon, O.H., Cho, S.M. and Hwang, S.M. (2008) Design and implementation of Fire alarm system
- [4]. BBC NEWS ASIA (25 November 2012) Dhaka Bangladesh Clothes Factory Fire Kills more than 100.
- [5]. Cot, A. and Bugbee, P. (1988) Ionization Smoke Detectors. Principle of Fire Protection. National Fire Protection Association, Quincy, 249.
- [6]. Northeast documents conservation centre, Nick Artim, an Introduction to Fire Detection, Alarm, and Automatic Fire Sprinkles.
- [7]. <http://www.bbc.com/news/world-asia-20482273>
- [8]. Safelincs-Fire Safety Products. <http://www.safelincs.co.uk/>
- [9]. Atmel (2014), Atmega8. <http://www.atmel.com/devices/atmega8.aspx>
- [10]. Micron Electronics (2014), SIM300CZ GSM/GPRS MODULE. [http://www.simcom.us/product\\_detail.php?cid=1&pid=2](http://www.simcom.us/product_detail.php?cid=1&pid=2)
- [11]. Mikroelektronika (2014) mikroC PRO for AVR. <http://www.mikroe.com/mikroc/avr/>
- [12]. CadSoft Computer (2014) CadSoft EAGLE PCB Design Software. <http://www.cadsoftusa.com/eagle-pcb-design-software/>