

Active And Reactive Power Control Using Renewable Energy Sources

¹puja P.Mahajan (Pg.Student) ²pradnya Parate (Guide)

Department of Electrical engineering

¹AbhaGaikwadPatil College of Engineering²AbhaGaikwadPatil College of Engineering&Technology, Nagpur, India & Technology, Nagpur, India

Abstract: This work presents related to the management of active and reactive power exchange between a distributed generation (DG) source and the grid connected for improved utilization of electricity generated by the DG source such as solar & wind energy. This is based on the recently introduced Availability Based Tariff (ABT) concept for the consumer loads, where the conventional power grid is available. In situations, when, the grid power is available at high cost during high electrical tariff, the locally generated power from solar is utilized for consumer loads or even excess power can be fed back to the grid in order to earn financial benefits. In addition to current control and voltage control, power quality control is made to reduce the total harmonics distortion. This work offers an increased opportunity to provide distributed generation (DG) use in distribution systems as a reliable source of power generation to meet the increased load demand which helps to provide a reasonable relief to the customers and utilities to meet the increasing load demand. In this paper, we are comparing different technique for power control in RE system like wind and solar.

Keywords: Grid interactive inverter, Voltage Controller, Current Controller, THD Improvement, Reactive power compensation

I. Introduction

As of late the number of technological improvements on the outline of models for energy power by utilizing energy sources not traditional, for example, sun based wind, hydro, biomass and bio fills, geothermal, cells powers . Sustainable power sources, for example, Solar Energy and Wind energy are the sources that energy caught and put away by nature. Because of global warming, new energy sources should be utilized for example, sun oriented and wind energy..

Other energy source can compensate for the difference, when a source is unavailable or insufficient in meeting the load demands. Due to the rapid growth of power electronics techniques applications with photovoltaic (PV) energy and wind energy have been increased significantly. Basically solar radiation and wind speed are complementary profiles. The communities outside the urban centers have problems for installation, wiring because the public does not arrive to their homes.

Reactive power control methods are discussed in. These methods are much complicated and require sophisticated measurement and signal processing. The work presented here is about the generation of AC power from solar; the control of active and reactive power flows into the grid, and getting financial benefit from the same.

Distributed Generators (DG) utilizing Environmental-friendly energy sources, like wind, small hydro, and solar have become a major part of the future smart grid/micro grid concept. These energy sources meet both the increasing demand for electric power and environmental regulations. Photovoltaic energy is one of the most popular renewable sources since it is clean, inexhaustible and requires little maintenance and 2 distributed throughout the earth. Active government policies are made to promote the need for tapping energy from the sun which is abundant in nature and to install standalone Photovoltaic (PV rooftop) technology to meet the increasing load demand and reduce the electricity bill of the customer. PV module cost is also decreasing, solar-based DG units –plays an increasing role in the power system of the near future.

DGs can be designed to provide ancillary services to the utility such as reactive power support, load An important aspect related to the PV system connected to the electric grid is that it can operate as both an active power generator and reactive power compensator. Voltage source inverter with current control is used for reactive power compensation in grid interconnection of solar-based DG. DG system can feed power into the AC grid through a grid-connected inverter, there is no need for a storage battery, and this will leads to minimizing the cost of installation.

The basic requirement of a grid-interactive inverter operation are active power generator, reactive power compensator and must able to maintain the voltage magnitude at the point of common coupling(PCC) to the desired value.. Single-phase grid-interactive inverter in grid-connected mode with resistive load has been

presented. The aim of this work is to select a control and switching strategy for an inverter which is to be used as part of a single-phase rooftop grid-connected PV system capable of improving the power quality in terms of power factor and low THD.

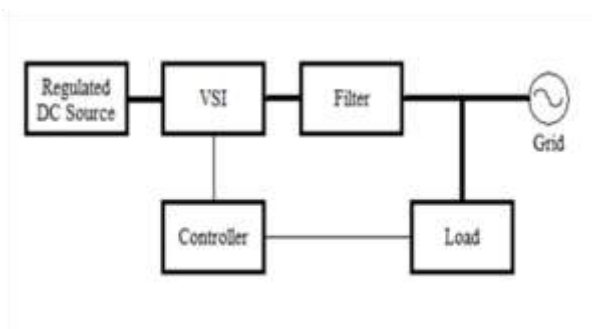

Fig. 1 Block diagram of solar and wind connected grid.

II. Renewable Energy Sources

A renewable electricity generation technology harnesses a naturally existing energy flux and converts that flux into electricity. It must be located at the place where natural energy flux is available to occur. This technology is differed from the conventional fossil-fuel and nuclear electricity generation.

III. Wind Energy

Figure 2 represents a basic block diagram to produce electricity using wind turbine. It consists of two or three propeller or blade at the top of the turbine around a shaft. The wind circulation creates force on the shaft to rotate the rotor of the generator which produces electromagnetic induction. The flux across the conductor is changed to produce electricity. Two types of propeller are used in the wind turbine, namely drag type and lift type. The drag type propeller has higher torque and slow rotating speed. Horizontal Axis Wind Turbine (HAWT) uses lift type propeller. Lower air pressure is created on the leading edge while higher air pressure is created at the tail edge.

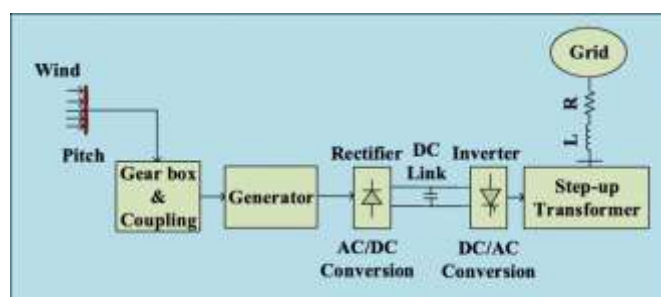

Fig. 2 Wind Energy Generation Process

Induction generator consumes more reactive power. To overcome this problem, double fed induction generator (DFIG) is widely used. An inverter is used that controls the torque and real and reactive power of the machine by controlling the current.

IV. Solar Energy

A basic block diagram to produce electricity using solar system is represented in Fig. 3. Solar system consists of solar cells that convert the light energy into electricity. When the photons of the sunlight hit the solar cell, it absorbs the photons.

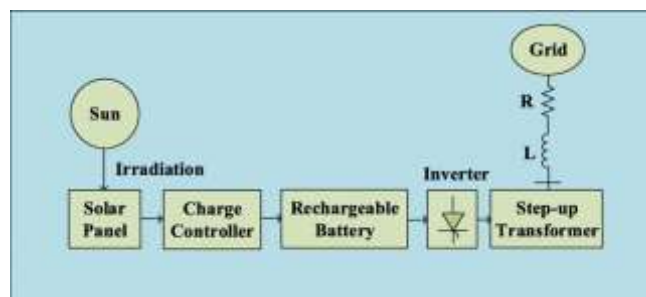

Fig. 3 solar energy generation process

The current produced by the solar system is known as light-generated current. The photons absorbed by the solar cell produce electron-hole pairs. The carriers are collected by using a p-n junction to separate the electron and hole. When the minority carriers reach to the p-n junction, it is swept by the electric field. By connecting the emitter and base together, the light generated by carriers flows through the external circuit.

V. Different Stages Of Operation

Stage I-

Wind power now represents a major and growing source of renewable energy. Large wind turbines (with capacities of up to 608 MW) are widely installed in power distribution networks. As its level of grid penetration has begun to increase dramatically, wind power is starting to have a significant impact on the operation of the modern grid system. Advanced power electronics technologies are being introduced to improve the characteristics of the wind turbines, and make them more suitable for integration into the power grid. First, the state-of-the-art technology and global market are generally discussed. Several important wind turbine concepts are discussed, along with power electronics solutions either for individual wind turbines or for entire wind farms.

The individual power ratings and installations of wind turbines have been significantly increased over recent decades, such that wind energy now plays an important and growing role in power systems. A main driving factor is represented by the continuous need for sustainable and renewable energy at competitive prices.

Stage II-

End consumer of energy is getting more cautious of their environmental footprint and with the cost of renewable energy sources like photo-voltaic solar progressively declining, it is expected that the percentage contribution from these new and renewable sources in overall power generation will increase. However, the renewable energy sources carry their own set of drawbacks which is slowing their widespread acceptance. First and foremost is the variability in generation, then controlling the power output from solar is also not trivial since the generation is highly dependent on the external factors such as solar irradiance.

Furthermore, there is a mismatch between the demand profile from the consumer and the supply profile of solar. This increased integration of renewable sources in the present grid creates a set of problems such as over voltage, power back flow and instability. We propose a curtailment based solution to the problem of over production. We provide an algorithm which controls the power output from solar panels. It delivers maximum possible power during the times of low irradiance and curtails the power output during the times of peak generation. With real-data on solar panel output across multiple presumes, we are able to demonstrate the effectiveness of the proposed algorithm. Increasing awareness among citizens, progressively declining energy costs from solar, and subsidies provided by the government have led to increased share of solar PV in the energy market. After initial capital investment, energy from solar is virtually maintenance free which makes it a lucrative energy source. However it has its own sets of limitations of variability and over production during peak hours. Some technology challenges and future solutions for power electronics in wind turbine systems are also addressed.

Stage III-

Maximum power point tracking is a technique commonly used with wind turbines and PV solar systems to maximize power extraction under all conditions. Although solar power is mainly covered, the principle applies generally to sources with variable power. PV solar systems exist in many different configurations with regard to their relationship to inverter systems, external grids, battery banks, or other electrical loads.

Fuzzy controllers are implemented by three inputs- error, Derivative of error and integration of error. The fuzzy controller is feedback loop and computes PID-like actions through fuzzy inference. Degree of membership

function lie in the range of -1 to 1 and the range of universe of discourse is also from -1 to 1. Membership function is triangular in shape. Fuzzy PID Controller used in system to improve the output.

Stage IV-

The control of the output power of a solar/wind stand-alone system. The control system regulates the generation of the wind subsystem in order to satisfy, jointly with the photovoltaic generation subsystem, the load and battery charge power demand. The controller is designed using a theoretical framework that unifies passivity and sliding mode techniques. The resultant control law does not need wind measurement and only relies on rotational speed and current measurements. An analysis of the acceleration estimate error is carried out and a countermeasure to compensate its effects is proposed.

A control strategy based on passivity and sliding mode techniques was developed in order to regulate the power output of a stand-alone hybrid system, which comprises wind and photovoltaic generation, a battery bank, and is intended for ac supply. This is a significant feature because controllers designed for complex control objectives, usually, require information of the wind.

VI. Conclusions

This paper presents the use of renewable energy sources and production methods of electricity. Active and Reactive power control using solar and wind (Renewable energy) connected grid. The hybrid generation system is comprised of solar photovoltaic (PV) and wind turbine (WT). The future world will largely depend on the use of renewable energy sources to maintain the daily need for electricity.

The performance of proposed MPPT technique-based controller performance is verified during different radiations of sunlight during day time with different time interval. It is clearly evident that proposed MPPT technique-based controller improve the utilization of solar power during different time period within the day time. The Fuzzy PID Controller is made non-linear control table and is made to perform by fine tuning. Step response of fuzzy PID Controller gives low overshoot, less setting time, less rise time and low integrals absolute error than the conventional PID controller.

References

- [1]. Wang, Q., Cheng, M., Jiang, Y., Zuo, W., & Buja, G. (2018), "A Simple Active and Reactive Power Control for Applications of Single-Phase Electric Springs", *IEEE Transactions on Industrial Electronics*, 65(8), 6291–6300.
- [2]. DehghaniTafti, H., Maswood, A. I., Konstantinou, G., Pou, J., & Acuna, P. (2018), "Active/reactive power control of photovoltaic grid-tied inverters with peak current limitation and zero active power oscillation during unbalanced voltage sags", *IET*.
- [3]. Bisht, R., Subramaniam, S., Bhattarai, R., & Kamalasadana, S. (2018), "Active and reactive power control of single phase inverter with seamless transfer between grid-connected and islanded mode", 2018 IEEE Power and Energy Conference at Illinois (PECI).
- [4]. Andran, A. S., & Lenin, P. (2018), "A review on active & reactive power control strategy for a standalone hybrid renewable energy system based on droop control", 2018 International Conference on Power, Signals, Control and Computation (EPSCICON).
- [5]. Viswadev, R., Ramana, V. V., Venkatesaperumal, B., & Mishra, S. (2018), "Real and reactive power control of solar grid-tie inverter under distorted grid conditions", 2018 International Conference on Power, Instrumentation, Control and Computing (PICC).
- [6]. Gui, Y., Kim, C., Chung, C. C., Guerrero, J. M., Guan, Y., & Vasquez, J. C. (2018), "Improved Direct Power Control for Grid-Connected Voltage Source Converters", *IEEE Transactions on Industrial Electronics*, 65(10), 8041–8051.
- [7]. Paghdar, S., Sipai, U., Ambasana, K., & Chauhan, P. J. (2017), "Active and reactive control of grid connected distributed generation system", 2017 Second International Conference on Electrical, Computer and Communication Technologies (ICECCT).
- [8]. Son, J.-Y., & Ma, K. (2017) "Wind Energy Systems", *Proceedings of the IEEE*, 105(11), 2116–2131. 10) U.S. Department of Energy. Office of Electricity Delivery and Energy Reliability, Recovery Act Financial Assistance Funding Opportunity Announcement, Smart Grid Investment Grant Program, DE-FOA-0000058, June 25, 2009.
- [9]. M. Garcia-Sanz and C.H. Houppis. *Wind Energy Systems: Control Engineering Design*. Boca Raton, FL: Taylor & Francis, 2011. IRENA. (Jan. 2015).
- [10]. Wang, Guishi et. al., "Power smoothing of large solar pv plant using hybrid energy storage," *IEEE Transactions on Sustainable Energy*, 2014.
- [11]. D. C. Drago and G. Adrian, "Modeling of renewable hybrid energy sources", *Scientific Bulletin of the Petru Maior University of TirguMures*, Vol. 6, 2009.
- [12]. J. Hui, "An Adaptive Control Algorithm for Maximum Power Point Tracking for Wind Energy Conversion Systems", Department of Electrical and Computer Engineering, Queen's University, December 2008.
- [13]. Bakhshai et al., "A Hybrid Wind – Solar Energy System: A New Rectifier Stage Topology", *IEEE Magazine*, July 2010.
- [14]. R. Bharanikumar and A. Nirmal Kumar, "Analysis of Wind Turbine Driven PM Generator with Power Converters", *International Journal of Computer and Electrical Engineering*, Vol. 2, August, 2010.
- [15]. Villalov M.G, Gazoli, J.R and Ruppert Filho, E, 2009, Sept. Analysis and simulation of the P&O algorithm using PV array. In conference2009.