

Hybrid Power System For Vsc HvdC Using Matlab

Tejaswinipatilprof. Pradnyaparate

PGstudent.Assistant professor.

*Department of Electrical engineering Department of Electrical Engineering
AbhaGaikwadPatil College of EngineeringAbhaGaikwadPatil college of Engineering
Nagpur, India.*

Abstract—Presently strength system operates beneath a excessive pressure degree which modified into not noted at the instant they were designed. The operating situations of strength system are being threatened shape the reliability, controllability and security factor of view. HVDC transmission brings a way to have at ease and improve the steadiness margins of strength machine. The feature like independent control of real and reactive electricity improves the strength device stability and guarantees an inexperienced power switch. This Project gives the manipulate strategy used for VSC-HVDC transmission to improve the quick and voltage stability of strength gadget. Transientinstability due to a device faults overcome because of the fast energy run again capability of the VSC-HVDC transmission. VSC-HVDC prevents the tool from quick instability via its instant electricity reversal capability. The voltage help functionality of VSC gadget helps to shield the gadget from voltage fall apart, finally losing of synchronism may be avoided. A grid related lower lower back to again VSC-HVDC modeled in MATLAB/ Simulink environment and a current mode control approach have become finished. The simulation turned into completed to have an statement of a quicker and impartial manipulate of real and reactive strength.

Keywords—VSC-HVDC, stability, pulse width modulation (PWM)

I. Introduction

THE GROWING complexity of EPS (electric power sys-tem) poses new challenges to ensure its reliability andstability. At the same time, the progress achieved in powerelectronics has demonstrated the HVDC (High-voltage directcurrent) technologies effectiveness in solution of conventionaltasks such as asynchronous interconnection, long distancetransmission, increasing the local and systemic controllabil-ity of EPS, as well as the relatively new challenges relatedwith integration of the distributed renewable energy sourcesinto HVAC (High-voltage alternating current) system [1]–[3].Converter based on power semiconductor is the main ele-ment of these technologies. Currently, the scheme of HVDCbased on two types of converters - line commutated con-verter (LCC) and voltage-source converter (VSC) - is usedin EPS. It should be noted that VSC based on fully con-trolled high-speed power switches (IGBT, GTO) has several advantages compared to LCC [2], [4], [5], such as:

- the independent control of active and reactivepower;
- the provision of reverse of power flow without changing the polarity of thevoltage.

At the same time, the possibility of parallel-series connec- tions and a high speed commutation of power semiconductor (switching time of the IGBT (Insulated-gate bipolar transistor) is 5 μ s) allow the formation of a more sinusoidal wave of volt- age,whichconsequentlyreducestheTotalharmonicdistortion, and as a result, the optimization of parameters of the HVDC filter on the AC (alternating current)side.

TheflexibilityandhighspeedcontrollabilityofVSCHVDC enable to use them as additional voltage regulation and damp- ing of low frequency oscillations in the EPS, caused by a short circuit,disconnectionofgeneratorsandetc.[1],[6].

Nevertheless,thepracticalnecessityofrelevantresearchand analysis to ensure safe and reliable operation of these tech- nologies and EPS in general are emphasized by many research groups and engineers[7]–[9].

The most complex and urgent tasks include [10], [11]:

- the analysis of the mutual influence of HVDC and HVAC systems, including their control and protection upon each other and the EPS as the whole, especially in transient conditions;
- the development, testing and adjustment of the local and systemic automatic control and protection systems.

A solution of these tasks requires full-scale experiments in real EPS, which cannot be conducted. Therefore, the control and monitoring system (like a Wide Area Control System) and hard- and software simulation tools are the main sources used to obtain the information required for analysis of the EPS operation [8]. Study of experience of their application in practice allows us to define advantages and disadvantages of these approaches

and identify promising directions of the development of methods and tools of EPS analysis. One of the most striking examples of the application of the control and monitoring system for the EPS analysis containing HVDC technologies can be viewed in the EPS of South China [8]. According to [8], the received for several years emergency shutdown data of HVDC, that led to cascading failures and separation of EPS, ensured the development of effective configuration of automatic control system (ACS) of hybrid HVAC and HVDC systems and the prevention of similar accidents in the future.

There are some weaknesses in this approach:

- the high complexity associated with the analysis of disturbance processes in case of low observability of the EPS;
- the limited applicability of the measurement results to set up the ACS of hybrid HVAC and HVDC systems;
- the occurrence of previously unobserved disturbances;

2

- the existence of a wide range of all possible pre-emergency modes of EPS;
- the significant time resources required for the various experiments in a real EPS and further analysis of obtained results.

That is why the control and monitoring system can not be regarded as a primary source of information for the analysis of the mutual influence of HVDC and HVAC systems. However, it can be used to verify the results of EPS simulation [8], [9]. At the same time, the reliability and adequacy of the simulation results will depend on the chosen simulation methods and tools.

The rest of this paper is organized as follows. Section II introduces the HVDC simulation challenges and proposes alternative tools based on hybrid real time simulation concept. Section III presents the VSC HVDC simulation including adequate representation of commutation process of real IGBT and experimental research of the 2-level VSC HVDC model in EPS. Conclusions are stated in Section IV.

II. The Simulation Challenges

To solve the problem of the reliability and adequacy of the simulation processes in a real VSC HVDC the modeling system should take into account the specifics of the operation of these devices, in particular:

- the phase-phase operation of VSC;
- the use of high-speed fully controlled power semiconductors;
- the continuous high-speed operation in all possible normal, emergency and post-emergency operating conditions of EPS.

Furthermore, to solve the above mentioned problems, the simulation systems should meet the following requirements [10], [12], [13]:

- the models of EPS elements must be three-phase (or more) to account properly for all the unbalanced conditions;
- the simulator must be capable (scalable) to implement an EPS model of any size;
- the simulation of EPS must exclude the decomposition of processes and limitations on their duration (without separation of electromagnetic and electromechanical transient processes modeling in power equipment and EPS as a whole);
- the real-time simulation and the possibility of interconnection with external devices and systems.

Currently, digital modeling complexes are widely used for analysis of the EPS (RTDS, HYPERSIM [9], [14] and others). These complexes have shown to be successful in the simulation of electromagnetic transients and closed loop testing of ACS, but the numerical integration methods used in digital simulation tools do not enable to perform real time simulations of EPS without processes of decomposition over an unlimited period of time because of the integration time step issue.

Additionally, the digital simulation of large EPS is affected by problems associated with the limitations on the size of a model solved by a single processor. Thus, the model partitioning and application of the travelling wave transmission line models to connect the parts of a power system model distributed between several processors is required. A trick of the application of the travelling wave model is that a traveling time of a transmission line has to be greater or equal to an integration time step which is not always accessible and thus may require forced correction of inductance and capacitance values of a transmission line model.

The distribution of EPS model limits the number of processors, that can be connected to one node, and leads to forced simplifications and equivalent representations of power equipment and EPS models. These limitations of digital modeling complexes are shown in simulation of short transmission line (in back-to-back HVDC system), or simulation of Multi-terminal HVDC projects with a short DC (direct current) link [15].

At the same time the issue of simulating in real time large EPS without separation of electromagnetic and electromechanical transient processes is not solved in full [16], [17]. This statement is confirmed by observed trends in research and development of hybrid simulation tools, based on application of different numerical simulation

methods [7],[15]–[17].

However, after the detailed analysis of some of mentioned in [16] and [17] hybrid complexes obviously that required detailed and comprehensive modeling of EPS is not fully achieved. Thus, in [17] to analyze the processes caused by faults in HVDC converters authors used simulation time step around $50 \mu s$, whereas the switching time of Gate turn-off thyristor is about $30 \mu s$, for IGBT $5 \mu s$. Besides the data exchange between the used complexes is carried out with bigger simulation time step than the simulation time step of electromagnetic transients modeling.

To solve mentioned issue of real time simulation of HVDC systems and EPS as a whole, the hybrid simulation technology based on the application of analog, digital and physical modeling approaches and realized in Hybrid Real-time Simulator of EPS (HRTSim), developed in Tomsk Polytechnic University, is proposed.

The results of the development and research of the VSC model, realized in HRTSim, are shown in this article.

A. The Concept of Hybrid Simulation of EPS

The concept of hybrid simulation is based on the use of three modeling approaches: analog, digital and physical, each of which achieves maximum efficiency in solving individual subtasks. A detailed description of the concepts and tools is presented in [18] and [19].

The basic points of the concepts are:

- the power equipment of EPS is described via complete systems of differential equations adequately representing the whole significant range of quasi-steady and transient processes in this equipment and forming comprehensive mathematical models of corresponding types of the simulated equipment;
- the methodologically accurate with guaranteed instrumental errors solution of differential equations systems in real

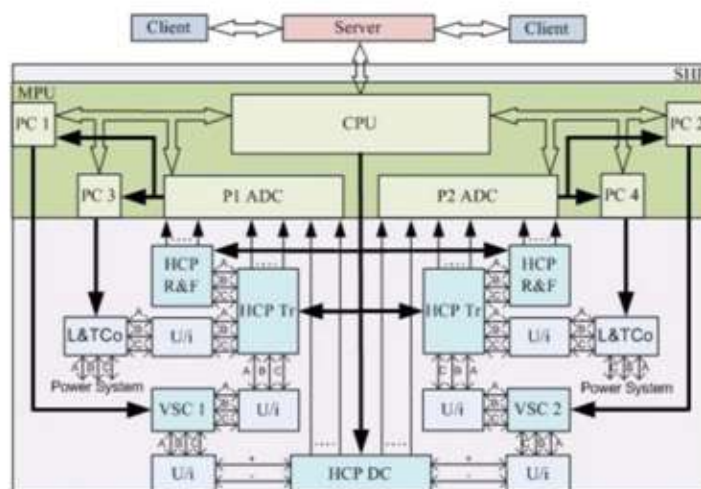

Fig.1. The structural diagram of the SHP of the VSC HVDC model: MPU - microprocessor unit; CPU - central processing unit; P1 ADC and P2 ADC - processors of analog-to-digital converters;

time and over an unlimited period of time are carried out by means of the continuous implicit integration method;

- all types of commutation of power equipment, including the power semiconductors, are carried out on a model physical level;
- the interconnection between a physical model and mathematical simulation levels is provided by means of appropriate voltage-current converters;
- a mutual conversion of mathematical and model physical variables in conjunction with simulation on the physical model level of the commutation of power equipment provides the ability of unlimited scalability of the simulated EPS;
- all informational and control functions, as well as modeling control and protection systems are implemented on a digital level using a digital-to-analog, analog-to-digital conversion and specialized local and server software.

The given concept is realized in the specialized software and hardware hybrid complex - Hybrid Real-Time Simulator (HRTSim) of EPS.

Specialized hybrid processor (SHP) is the basic element of the modular structure of the HRTSim and provides an adequate comprehensive simulation in the real-time of power equipment models, as well as control and protection systems.

In Figure 1 and 2 the structure and appearance of the developed experimental SHP of the 2-level VSC HVDC

model areshown.

According to the above concept, the solution of comprehensive mathematical models of the simulated equipment is carried out via the hybrid coprocessors(HCP).The result of solution is transmitted to the MPU (microprocessor unit) via the PADC (processors of analog-to-digital converter). The wholerangeofdatatransformationsrequiredtooverseetheprocess of simulation, as well as real-time control of parameters of the modeled power equipment, depending on the desired solution speed of a control algorithm, are implemented in the MPU.

The universality of the concept and modular structure of the HTRSim allow the development of a model of any element of EPS, including devices and HVDC, and to integrate them into the HTRSim, as well as to provide interconnection with various external software and hardware tools: operational information systems, SCADA system etc.[20].

III. Vsc Simulation

To createanadequatemodelofHVDCitisnecessarytoprovide completeness and accuracy of the process description in the steady-state and transient operating conditions, determined by modeling implementation errors at all the mentioned digital, analog, and physical levels of simulation. Digital simulation is carried out only for the control system of HVDC.

Modeling errors at the physical model level lead to a deviation of loss level, distortion of voltage and current waveforms on both the DC and AC side in the significant frequency spectrum of the EPS. Based on this, the simulation of process at the physical model level is critical to the modeling results, especially for the pulse mode of VSC. Errors at this level can be caused by incorrect characteristics of power semiconductors or parameters of the DC circuit. The latter problem is successfully solved by the selection of components. The characteristics of the physical models of power semiconductors require additional analysis and will be addressed in future works.

A. Simulation of Commutation Process

As mentioned above, the physical model level is particularly important, because at this level an operation of power switches is modeled via integrated microelectronic digitally controlled analog switches(DCAS).

Consequently, the equivalent circuit of DCAS can be adapted to simulate real power switches. Analysis of equivalent circuits of DCAS and real IGBT (type 5SNR), a comparison of their parameters, taking into account modal and technical scaling coefficients were carried out to verify the adequacy of this simulation.

It should be noted that the character of the transition process can be adapted by appropriate selection of parameters

IV. Conclusion

The specialized concept of a hybrid simulation and the results of its experimental realization show the possibility and efficiency of the proposed approach to the development of the models of power semiconductors and VSC implemented on them.

The obtained results allow us to carry out a detailed representation of commutation process of IGBT and adequate modeling of spectral analysis of VSC, as well as comprehensive real-time simulation of all the processes in HVDC and EPS as a whole without any decomposition and limitation on their duration.

References

- [1]. P. Thepparat, D. Retzmann, E. Ogée, and M. Wiesinger, "Smart transmission system by HVDC and FACTS," in *Proc. IEEE Towards Carbon Free Soc. Through Smarter Grids*, Grenoble, France, Jun. 2013, pp.1–6.
- [2]. A. L'Abbate et al., "The role of facts and HVDC in the future pan-European transmission system development," in *Proc. IEEE 9th IET Int. Conf. AC DC Power Transm.*, London, U.K., 2010, pp.1–8.
- [3]. D. Povh, "Use of HVDC and FACTS," *Proc. IEEE*, vol. 88, no. 2, pp. 235–245, Feb.2000.
- [4]. J. Zhu and C. Booth, "Future multi-terminal HVDC transmission systems using voltage source converters," in *Proc. 45th Int. Univ. Power Eng. Conf.*, Cardiff, Wales, 2010, pp.1–6.
- [5]. L. Bertling and J. Setreus, "Introduction to HVDC technology for reliable electrical power systems," in *Proc. 10th Int. Conf. Probabilist. Methods Appl. Power Syst.*, Rincón, Puerto Rico, 2008, pp.1–8.
- [6]. N. M. Tabatabaei, N. Taheri, and N. S. Boushehri, "Damping function of back to back HVDC based voltage source converter," *Int. J. Tech. Phys. Probl. Eng.*, vol.2, no.3, pp.82–87, Sep.2010.
- [7]. L. Chen, K.-J. Zhang, Y.-J. Xia, and G. Hu, "Hybrid simulation of 500kV HVDC power transmission project based on advanced digital power systems simulator," *J. Electron. Sci. Technol.*, vol.11, no.1, pp. 66–71, Mar. 2013.
- [8]. D. Qi, "Defense schema against large disturbances in China Southern Power Grid," *Electra*, vol. 257, pp. 4–16, Aug.2011.
- [9]. B. M. Yang, C.-K. Kim, G. J. Jung, and Y. H. Moon, "Verification of hybrid real time HVDC simulator in Cheju-Haenam HVDC system," *J. Elect. Eng. Technol.*, vol. 1, no. 1, pp. 23–27, 2006.
- [10]. L. Zhi-Hui et al., "Modeling and simulation research of large-scale AC/DC hybrid power grid based on ADPSS," in *Proc. IEEE PES Asia-Pac. Power Energy Eng. Conf. (APPEEC)*, Hong Kong, Dec. 2014, pp.1–6.
- [11]. K. Ou et al., "MMC-HVDC simulation and testing based on real-time digital simulator and physical control system," *IEEE J. Emerg. Sel. Topics Power Electron.*, vol.2, no.4, pp.1109–1116, Dec.2014.
- [12]. L. Xu, Y. H. Tang, W. Pu, and Y. Han, "Hybrid electromechanical-electromagnetic simulation to SVC controller based on ADPSS

- platform,” *J. Energy South Africa*, vol. 25, no. 4, pp. 112–122, Nov. 2014.
- [13]. O. Nayak, S. Santoso, and P. Buchanan, “Power electronics spark new simulation challenges,” *IEEE Comput. Appl. Power*, vol. 15, no. 4, pp. 37–44, Oct. 2002.
- [14]. L. Snider, J. Bélanger, and G. Nanjundaiah, “Today’s power system simulation challenge: High-performance, scalable, upgradable and affordable COTS-based real-time digital simulators,” in *Proc. Joint Int. Conf. Power Electron. Drives Energy Syst. (PEDES) Power India*, New Delhi, India, Dec. 2010, pp. 1–10.
- [15]. P. A. Forsyth, T. L. Maguire, D. Shearer, and D. Rydmell, “Testing firing pulse controls for a VSC based HVDC scheme with a real time timestep $< 3 \mu\text{s}$,” in *Proc. Int. Conf. Power Syst. Transients*, Kyoto, Japan, Jun. 2009, pp. 1–5.
- [16]. Y. Zhang, A. M. Gole, W. Wu, B. Zhang, and H. Sun, “Development and analysis of applicability of a hybrid transient simulation platform combining TSA and EMT elements,” *IEEE Trans. Power Syst.*, vol. 28, no. 1, pp. 357–366, Feb. 2013.
- [17]. Z. Xiao-Xinet *et al.*, “Concept and mechanism on full-process dynamic real-time simulation of power system with parallel-in-time-space,” in *Proc. Int. Conf. Power Syst. Technol. (POWERCON)*, Hangzhou, China, Oct. 2010, pp. 1–7.
- [18]. A. Prokhorov, Yu. Borovikov, and A. Gusev, “Real time hybrid simulation of electrical power systems: Concept, tools, field experience and smart grid challenges,” *Int. J. Smart Grid Clean Energy*, vol. 1, no. 1, pp. 67–68, Sep. 2012.
- [19]. M. Andreev and A. Sulaymanov, “Platform based on hybrid real-time power system simulator for development and research of intelligent powersystems with active-adaptive networks,” in *Proc. IEEE Eindhoven PowerTech*, Eindhoven, The Netherlands, 2015, pp. 1–6.
- [20]. A. Prokhorov, Y. S. Borovikov, and A. S. Gusev, “Hardware-in-the-loop testbed based on hybrid real time simulator,” in *Proc. IEEE Innov. Smart Grid Technol. Europe*, Lyngby, Denmark, 2013, pp. 1–5.
- [21]. A. A. Andreas, “A novel test method for minimising energy costs in IGBT power cycling studies,” Ph.D. dissertation, Dept. Fac. Eng. Built Environ., Univ. Witwatersrand, Johannesburg, South Africa, 2006, pp. 1–207.
- [22]. L. Max, “Energy evaluation for DC/DC converters in DC-Based wind farms,” M.S. thesis, Dept. Energy Environ., Chalmers Univ. Technol., Gothenburg, Sweden, 2007, pp. 1–151.
- [23]. A. Prokhorov, R. Ufa, and A. Vasilev, “Synthesis of hybrid models for advanced simulation of HVDC systems,” *Int. J. Smart Grid Clean Energy*, vol. 3, no. 2, pp. 207–213, Apr. 2014.
- [24]. R. Ufa, V. Sulaymanova, and A. Gusev, “Hardware and software of real time simulation tools of electric power system for adequate modeling power semiconductor in voltage source converter based HVDC and FACTS,” in *Proc. MATEC Web of Conf.*, vol. 19, Les Ulis, France, 2014, Art. ID. 01029.