

Configuration Design of Spring Loaded Detachable Canister-Launch Vehicle Interface for Multistage long Launch Vehicle

Tarak Nath De¹, S Sundarrajan², G Krishna Mohana Rao³

1-Scientist-'C'; ASL,DRDO, Hyderabad.

2-Director; National Institute of Technology; Tiruchirappalli

Corresponding author:3-Associate Professor, Mechanical Engg Dept. JNTU;Hyderabad

ABSTRACT: - Canisterised multistage long range launch vehicle has the advantages of short launch preparation time, easy storage, easy transportation and camouflaging. Configuration design is carried out for a canister Launch vehicle (LV) interface which enables the horizontal dragging of LV into canister without damaging any protrusion on the LV body. The interfaces detach automatically during launch without help of any external pneumatically or electrically operated mechanism or pyro device. Interfaces are wrapped in three locations on the LV circumference. Interface assembly is made of two components a) spring steel strip and b) support block. Each interface assembly has spring steel strip passing through the discrete support blocks distributed around the LV circumference. The support blocks are specially designed for easy assembly/disassembly, easy entry/exit into/from intersection joints pockets and to withstand the LV load during the loading / rotation of LV inside canister. The spring steel strip passing through the support blocks is bent and held to circular arc to match the LV outer diameter with help of specially design gadgets. This paper explains the problem back ground, configuration design and design calculation, experimental evaluation and conclusion.

Key words: Canisterised Launch Vehicle, Flexible interface, Support block, Integration gadget

I. INTRODUCTION

Canisterised LV system will be cold launched using gas generator mounted at the aft end dome of canister. The canister in vertical condition LV is propelled out by the pressure generated by gas generator and once LV is completely out of canister Stage-I ignition will started at specified height from the ground. LV is loaded horizontally inside the canister using 'canister loading fixture'. During loading/unloading the LV into/out-of canister and during final launch, LV has to travel inside canister. LV has cylindrical portion as well as conical portions. Cylindrical portion of the LV has to be supported inside canister for any movement of LV inside canister. But there are number of projections on the cylindrical portion of the LV viz. FLSC strips, tongue and groove joints of motor etc. Total LV load has to be taken by these projections, which under very high bearing loads may fail. To avoid severe abrasion of LV surface as well as canister inner surface and also to protect all the protrusions on the LV, support blocks are mounted around the circumference of LV at three cross sections along the length of LV. Support blocks acts as interface between LV and canister and will be part of LV until getting discarded. LV will be resting as well as travelling inside canister on these support blocks assembly.

There are various kind of mechanism being used for canister LV interfacing worldwide for multistage long range LV system. Some of them are referred below. [1] A LV canister lateral support pad control system where in rods having flexible curved section are inter connected to the support pads and detachably held parallel to the LV by releasing means upon command, after LV leaves the canister, the releasing means allows the rods to spring away from the LV. This mechanism is analogous peeling of banana. But these supports can not withstand the pulling load of a multistage long range LV in horizontal condition. [2] Air bearing pads enable the installation of a large LV stages in a canister or removal of these from while the canister is positioned horizontally. Once the LV is loaded inside canister, the canister is rotated by 180° and when air pads come on the top these are replaced by semisolid lateral pads. For unloading the LV again the top semisolid pads are replaced back with air pads and brought to bottom location. So for this kind of interfaces canister LV rotation is compulsory for both loading and unloading. Different pneumatic accessories to operate the air pads should be part of loading/unloading fixture. Loading/unloading process can be simplified and duration can be reduced by avoiding pneumatic accessories and rotation of the canister. [3] A lateral support device system of a canister launched LV of the present invention is provided for eliminating the clearance between LV and canister in four places by 90 intervals and thereof no relative movements occur between the LV and the canister. When the LV starts to be launched, LV caught by pads by means of positioned adjustment pins. At the moments the LV blasts off after being highly accelerated within the canister the pads scatters in all the direction by restoration of force of corresponding spring. But using these pads LV can not be loaded in a horizontally positioned canister. Available mechanisms are not suitable for intended purpose of horizontal loading and automatic detachability.

II. PROBLEM DEFINITION

A canister LV interface has to be designed which withstands the bearing load due to the weight of LV at different cross section of the canister and distributes the load coming on to the canister surface due to LV weight. The interfaces should clear the maximum projection on the LV body. It has to withstand the frictional forces associated with the horizontal loading/unloading of the LV to avoid the huge infrastructure associated with vertical loading. These interfaces at different cross sections should discard automatically once LV comes out of the canister to increase the LV range by throwing unwanted mass and reducing drag. They have to fly off a sufficient distance to clear the launcher during launch. They have to restrict the wobbling of LV to minimum possible during launch of the LV. Its functionality should be retained over long storage life. It should be integrated easily before loading and disintegrated easily and safely during unloading of LV from canister.

III. CONFIGURATION DESIGN

Configuration design is carried out for a LV having 1500mm outer diameter and a canister having a 1600 mm inner diameter. At each joint of the LV 60 number of pockets are available for engaging intersection fasteners. 32 number of these pockets are used at each of the three stations. Fig 1 depicts the physical arrangement of configuration. There are three components of this canister LV interface assembly:

- Aluminium support block: acts a load bearing member between LV and canister and LV slides on these block during loading/unloading into/from the canister.
- Spring steel strip: acts as a spring loaded member when LV is inside canister and helps the interface face assembly to fly off automatically once LV is out of the canister.
- Gadget assembly: acts as an assembly/disassembly fixture before loading and during unloading.

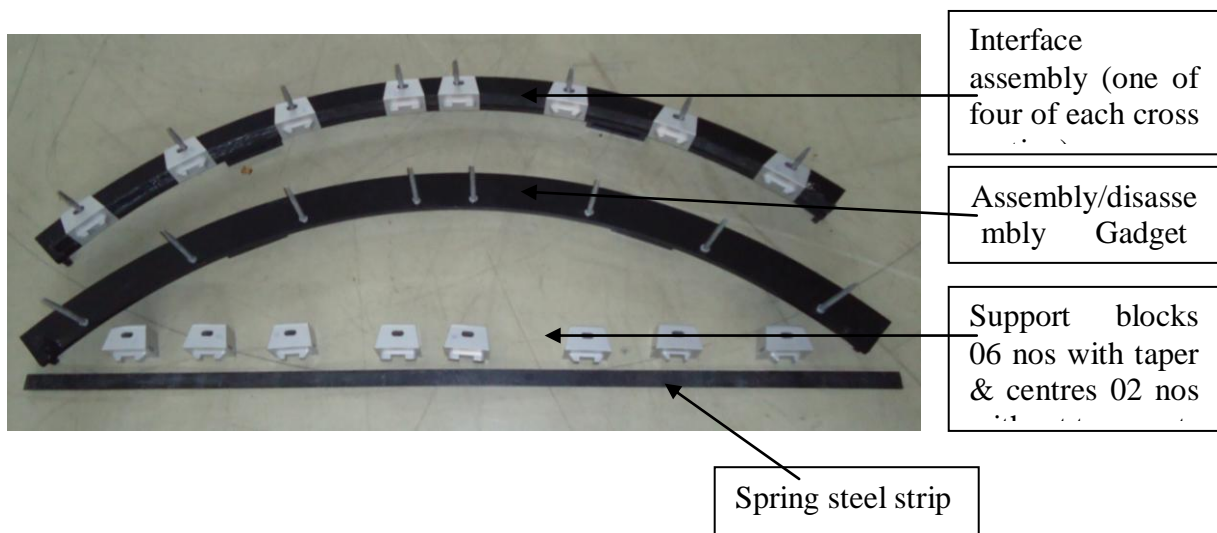

Fig1: Components of interface assembly

Three sets of support blocks are assembled at three different cross-sections along the length of LV. At each station, interface assembly consists of four number of spring steel strips wrapped around the circumference of LV. Each interface assembly has a spring steel strip passing through discrete aluminium blocks distributed around the LV circumference. Interface assembly station consists of four 1160 mm strip assemblies centred at top, right, bottom & left locations on LV. Individual support blocks are shown *Figure-2*. Support blocks are truncated trapezoid blocks whose bottom face will match with that of LV's outer diameter and top surface with canister's inner diameter. Rectangular slot in the direction around the LV circumference is provided in each support block through which spring steel strip passes. Rectangular slot with circular edges is machined through blocks along the axis of LV to engage gadget pin.

Configuration Design of Spring Loaded Detachable Canister-Launch Vehicle Interface for Multistage long Launch Vehicle

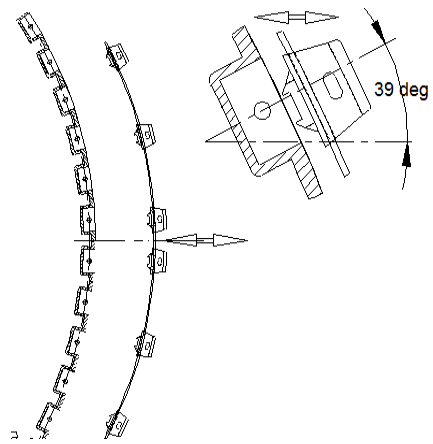
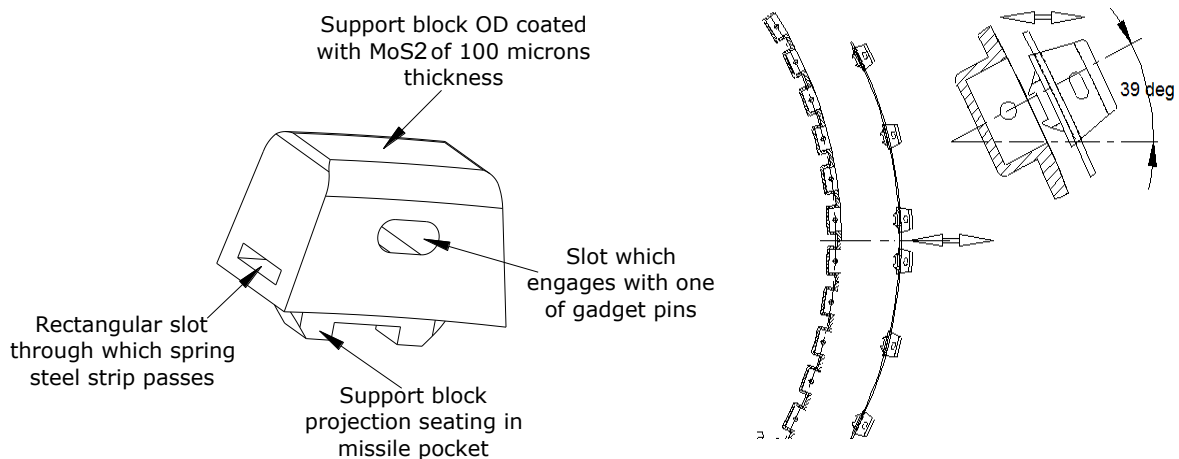

Figure 2: Features on support block Figure3:Block movement during assembly

Each support block will have a projection underneath, those seats inside the pocket of LV intersection joint. Pockets are discrete circular arc shaped slots provided on one of the mating aluminium bulk-heads of sections being joined. Pockets aid in leverage of spanner tightening the nut over the fastener so that mating bulkheads are pre-loaded in compression. Each interface assembly is bent to a circular arc to match with the outer diameter of LV using gadget as shown in the *Fig1*. For assembly with LV, center axis of each of four strips moves radially towards the LV's pockets. In turn, the individual support blocks of each strip assembly tread a linear path, whereas the slots of pocket are in radial direction. And also during discarding, the projection of support blocks will not follow a radial path out of pocket; instead they will follow an involutes path as depicted in *figure-3*. To meet these requirements, all the support blocks in each of the interface assemblies is given a positive taper of 40° , except for the two center blocks which are made in same shape of pocket slot (with out any taper) with 2.5 mm clearance with pocket edges. Since the two center blocks are near the center line of interface assembly, there is only slight deviation of the linear path followed by two center blocks from the radial slots of corresponding pockets which can be catered well by 2.5mm clearance provided. These two center blocks bear the frictional load during the rotation of LV inside canister.

Gadget is an annular steel plate, with discrete tapered pins fastened at locations to match with the distribution of support blocks around the LV circumference, so that support blocks seats perfectly, once each interface assembly is engaged in pockets of LV. The optimum values of thickness and width of gadget is decided to maintain a balance between stiffness and ease of handling of gadget. The initial taper of pins enable easy engagement of gadget to corresponding slots of support blocks, the straight portion of pin that follows enable proper support blocks seating in pockets with out tipping about maximum pin diameter. Gadget is also provided with additional features at the ends as depicted in the *figure4*. The ends of spring steel strip is constrained only by the end support blocks which are again constrained by end tapered pins of gadget which allows roll DOF for end support blocks. So the edge of the strip springs back, which rotates the support block about pin. And also since the gadget stiffness is also limited to a extent, the edges of gadget tend to deflect because of spring back forces being exerted by spring steel strip, which will lead to end support blocks of strip assembly to push up from its intended position. To counter act these two effects, feature is welded at gadget ends, which is a plate with a threaded hole to engage a bolt. By tightening the bolt against the strip edge, both the above mentioned effects are counteracted, which will enable proper seating of end support blocks. Gadget should constraint the strip assembly until the LV is pulled inside canister i.e gadget and interface assembly once engaged in LV pockets should remain in position until the support blocks station is inside canister, then gadgets will be pulled back and spring back forces of strip will be taken by canister. To hold the gadget-strip assemblies in place, all the gadget assemblies should be fastened together so that gadget assemblies at bottom and sides get their support from top strip assembly and remain in their position. To cater for this requirement plate with rectangular slot is welded at gadget end as shown in figure 4 . With strip assemblies in place, these plates with rectangular slots will be facing each other. A bolt of appropriate length is inserted through these slots and nut is tightened so that adjacent gadgets will be fastened together. This will also counteract the end deflections of gadget due to spring back forces of spring steel strip.

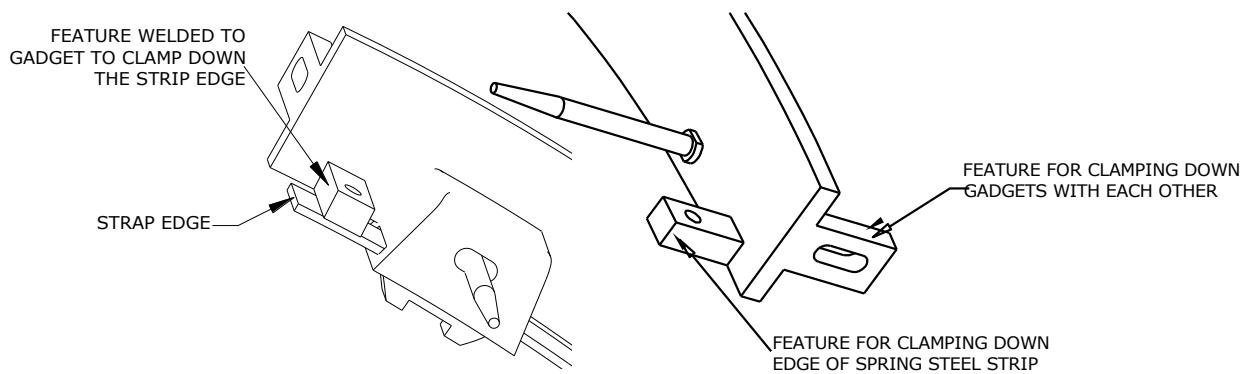

Figure 4: Gadget end features

Height of shoe block is an important parameter that can be adjusted to cater for the decrease in effective diameter of LV and that can be inserted through the canister because of tolerance stack up of LV as well as canister. Since the canister is stiffer than LV at support blocks stations, any local ovality of LV at support blocks station is corrected because of radial loads induced on LV during pulling. The bearing surface area of support blocks is decided in such a way that the resultant bearing pressure due to LV weight coming on canister is within allowable pressure load on canister. Support blocks with their projections are designed for the worst case scenario of projections coming in picture - to withstand the frictional forces associated with loading of LV into canister in horizontal condition and also during rotation of LV inside canister. Spring steel strips are designed to enable the interface assemblies to discard automatically and clear a minimum distance without damaging any part of the launcher once the LV is out of canister during launch.

IV. DESIGN CALCULATION OF SPRING BACK DISTANCE CALCULATION OF INTERFACE ASSEMBLY

Strain energy stored in a beam by bending is given by

$$U = \int \frac{M^2}{2EI} dx \quad \text{eq(1)}$$

where integral needs to be calculated over the length of beam. For spring steel strip $E = 200 \text{ GPa} = 200 \times 10^3 \text{ N/mm}^2$. Moment of inertia for the present case of bending $I = \frac{30 \times 4^3}{12} = 160 \text{ mm}^4$;

$$R=757\text{mm} \Rightarrow M = \frac{EI}{R} = \frac{200 \times 10^3 \times 160}{757} = 42272 \text{ N-mm} \quad \text{eq(2)}$$

Since EI/R is constant at all sections of strip, M is also constant from above equation. For one interface assembly with 8 support blocks, the energy stored in strip is

$$\Rightarrow U = \frac{42272^2}{2 \times 200 \times 10^3 \times 160} \int_0^{1160} dx \Rightarrow U = 32388 \text{ N-mm} \quad \text{eq(3)}$$

Weight of each support block = 0.43 kg and Weight of strip = 1.4 kg

Weight of one interface assembly = $(8 \times 0.43) + 1.4 \text{ kg} = 4.84 \text{ kg} \approx 5 \text{ kg}$

Assuming that all of this stored strain energy of spring steel strip will be converted to kinetic energy,

$$\Rightarrow U = \frac{1}{2}mv^2 \Rightarrow 32.39 \text{ N-m} = \frac{1}{2} \times 5 \text{ Kg} \times v^2 \Rightarrow v = 3.6 \text{ m/sec} \quad \text{eq(4)}$$

The above velocity is the horizontal velocity in radial direction of canister.

With canister in vertical direction and assuming that strip assembly has zero velocity in upward direction when it just leaves the canister, time it takes hit the ground say 19mts below is calculated by using equation

$$S = ut + \frac{1}{2}at^2 \quad \text{eq(5)}$$

in vertical direction. In vertical direction, $S = 2.5$ m, $u = 0$ m/s, $a = g = 9.81$ m/s²
 $\Rightarrow t = \sqrt{\frac{2S}{g}} = \sqrt{\frac{2 \times 2.5}{9.81}} = 0.71$ sec. In horizontal direction, $u = 3.6$ m/sec, $a = 0$
 $\Rightarrow S = ut = 3.6 \times 0.71 = 2.5$ m

Under ideal conditions one interface assembly falls 2.5 meter away from erected canister section of 2.5m height.

IV. EXPERIMENTAL EVALUATION

One of the Canister sections of 2500 mm height is used to simulate the canister and one of the LV sections of 2000 mm height is used to simulate the LV. Outer features and dimension of LV section and inner features and dimensions of canister section are same as actual LV and canister. Two stations of interface assemblies were mounted on either side of the LV section as shown in *Fig 5(a)*. The section is loaded into canister section in horizontal condition and gadgets are detached for each interface assemblies just before complete entry of interface assemblies into canister section. LV section loaded inside canister section in horizontal condition is shown in *Fig 5(b)*. Total assembly is made vertical and canister section is grouted to the floor. LV section is connected to the over head crane and pulled out of canister section as shown in *Fig 5(c)*. Fly out distances of each interface assemblies are noted down.



a: Canister

b: LV loaded in canister c: Assembly in vertical condition

Figure 5: Experimental setup

VI. CONCLUSION

This configuration has successfully functioned with a prototype model with a simulated condition for horizontal loading and automatic fly out of interface assemblies without any electrical assistance/pyro mechanism clearing a distance of 2.2 m from canister section. All the dimensional and shapes related to functionality of the interface assembly has been proven and standardized with the test. Assembly/disassembly of the interface assemblies has been proven using assembly gadget. Interface assembly has to be tested with full scaled configuration with simulated load condition and actual launch condition. There needs to be an optimization model for size selection of support blocks such that different sizes suits the different combination of LV and canister considering all the tolerance stack up of LV and canister. Such optimized combination will decrease the failure chances like jamming of LV inside canister or more wobbling of LV inside canister during launch or transportation. Proper tolerance model also to be generated to decrease the cylindricity error of both LV and canister by selecting proper combination of sections for the canister and LV.

Acknowledgements

Authors thank the authorities of ASL, DRDO, Hyderabad for granting permission to carryout the research work in and publish in journals.

Configuration Design of Spring Loaded Detachable Canister-Launch Vehicle Interface for Multistage long Launch Vehicle

Reference

- [1] Roy J. Heyman, "Missile Canister Lateral Support Pad Fly out Control System," United States Patent no.4430942; Feb.14, 1984.
- [2] Henry W. Beutler; Roland T.Ingels; Jack R. Kilgore, "Method and Apparatus for Loading / Unloading a Large Missile into/from a Horizontally Positioned Canister," United States patent No.4739691; Apr26, 1983.
- [3] Il-Soo Kim,Daejeon(KR);Woo-Jeon Shim,Daejeon(KR); Hak-Yeol Lee,Daejeon(KR), "A Lateral Support Device System for Canister Launched Missile," United States Patent Application Publication US2007/0175323; Aug2, 2007.