

Design & Implementation of Wireless Notice Board Display Based On Arduino and Bluetooth Technology

Aliya Farooque¹, Ashwariya sakhre², Balaji Bomade³ madhavi badole⁴, Ashvini Ughade⁵, Prof. Shyam D. Bawanker

Department of Electronics Engineering, D College Of Engineering And Menegment, Nagpur, India.

Abstract: *This document deals with an innovative rather an interesting manner of intimating the message to the people using a wireless electronic display board which is synchronized using the Bluetooth technology. This will help us in passing any message almost immediately without any delay just by sending a SMS which is better and more reliable than the old traditional way of passing the message on notice board. This proposed technology can be used in colleges many public places, malls or big buildings to enhance the security system and also make awareness of the emergency situations and avoid many dangers. Using Bluetooth module display the message onto the display board. and GSM module send the SMS to the student or register number. The Electronic notice board is wireless and no need of wires for displaying the information on the LCD Display. It is very easy to operate and consumes less power. The circuit of the wireless notice board is portable.*

Keywords: *Arduino, ATmega328p, LCD Display, Bluetooth Module, GSM Module, Android Application.*

I. Introduction

Wireless technology has a tremendous progress over the past few years. The ever-increasing use of wireless networks serves as an indicator of the progress in the area of wireless networks. As a means of communication, notice board are widely trendy with its applications ranging from schools, colleges, hospitals to major organizations. Notice boards effectively tackle the global problem of deforestation by conveying messages at large without the use of paper. The design of SMS driven automatic display Board which can replace the currently used programmable electronic display and conventional notice board. It is proposed to design receive cum display toolkit which can be programmed and later be used from an authorized mobile phone. It consists of arduino board, controller AT mega 328P, Blue tooth .mobile phone and LCD display board. LCD display board is used for testing the proposed model. The interfacing of a arduino board with mobile phone is quite easy with help of the terminal pin, read/write pin. Hence we employ Atmel ATmega328p microcontroller. The complexity of coding of our proposed system is less as compared with PC, but once programmed the micro controller works at its best. The design procedure involves identifying the different components and assembling all of them and it makes proper communication. Then coding process has to be done, which has to take care of the difference between two successive communications.

II. Material And Method

The main problem that prompts us to undergo this research work was the inability of display boards in most places particularly tertiary institution to be easily updated. This work seeks to eliminate this challenge by allowing for easy update of notice board electronically via GSM Network. The message that is to be displayed is sent through an SMS from a mobile phone to the authorized in the Bluetooth module. The microcontroller receives the SMS from the authorized transmitter, validates the sending Mobile Identification and displays the desired information on the Liquid Crystal Display (LCD) which serves as the notice board. And send the SMS to the Student.

III. Ease Of Use Block Diagram

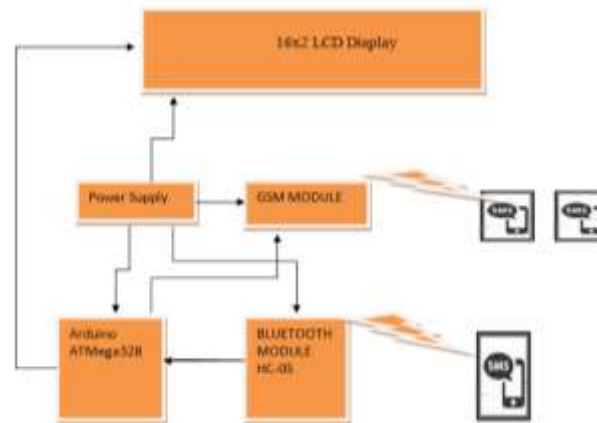

Figure 1: Block Diagram

The above block diagram represents our proposed ‘Design & Implementation of Wireless Notice board display based on arduino and Bluetooth and GSM Technology’ system.

3.1 GSM MODULE:

A GSM modem is a specific type of modem which accepts a SIM card. It operates over a subscription to a mobile operator, just like a mobile phone. From the mobile operator perspective, a GSM modem looks just like a mobile phone. A GSM modem exposes an interface that allows applications such as NowSMS for sending and International Journal of Pure and Applied Mathematics Volume 118 No. 20 2018, 633-636 ISSN: 1311-8080 (printed version); ISSN: 1314-3395 (on-line version) url: <http://www.ijpam.eu> Special Issue ijpam.eu 633 receiving messages over the modem interface. At the time you install your GSM modem, or when connecting your GSM mobile phone to the computer, be sure about installing the appropriate Windows modem driver from the device manufacturer. The Now SMS & MMS gateway can concurrently support various multiple modems, provided that your computer hardware has the accessible communications port resources..

3.2 Arduino Uno (Atmega 328):

Arduino board is the heart of our system. Entire functioning of system depends on this board. The Arduino Uno is a ATmega328p microcontroller board. This board has 14 digital input/output pins (6 as a PWM outputs), 6 analog inputs, a 16 MHz crystal oscillator, a USB connection, a power jack, an ICSP header, and a reset button.

3.3 Power Supply:

This project utilizes a controlled 5V, 500Ma power supply, 7805 three terminal voltage controllers is utilized for voltage regulation. Bridge type full wave rectifier is utilized to rectify the ac output of secondary of 230/12V step down transformer.

3.4 Bluetooth Module (HC-05):

The HC-05 is a very cool module which can add two-way (full-duplex) wireless functionality. one can use this module to communicate between two microcontrollers like Arduino or communicate with any device with Bluetooth functionality like a Phone or Laptop. There are many android applications that are already available which makes this process a lot easier. The module communicates with the help of USART at 9600 baud rate hence it is easy to interface with any microcontroller that supports USART. We can also configure the default values of the module by using the command mode.

3.5 Android App:

BT Terminal is a terminal app with UART serial communication protocol that transmits & receives data wirelessly through bluetooth connections. The app can be used for Robotics Communication, Configuring Bluetooth Modules (using AT Commands), Home Automation, etc.

FEATURES:

1. Tested on HC-05 Bluetooth Module.
2. The app features both, transmitting and receiving data.
3. "Connect" and "Disconnect" buttons to quickly switch between connections without closing the app.
4. "Clear" button to clear all the received data, at once.
5. Single-page user interface for convenient usage.
6. Completely FREE! No Ads!



Figure 2: BT Terminal Android Application

The above figure is available on Google Play Store. Here in our project it used to give an input to our notice board from mobile phone.

3.6 LCD Display:

We utilize screen as display. LCD is utilized in a project to visualize the output of application. Liquid crystal displays (LCDs) have supplies which combine the properties of both liquids and crystals. With the liquid crystal material sandwiched in between them, an LCD consists of two glass panels. The inner surface of the glass plates are covered with transparent electrodes that identify the character, symbols or patterns to be displayed and the polymeric layers are present in between the electrodes and the liquid crystal, which makes the liquid crystal molecules for maintaining a defined direction angle.



Figure 2: LCD Screen

IV. Working

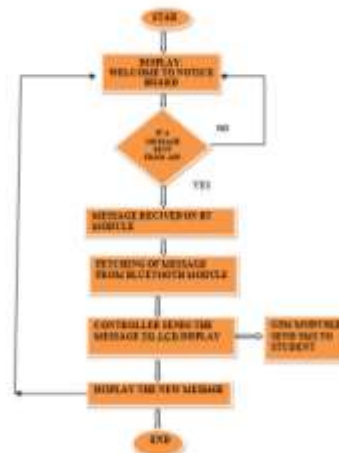

At first, LCD will display “DISPLAY: WELCOME TO NOTICE BOARD.” And after some delay, LCD will display the timetable continuously. If an authorised user wants to display some notice on this notice board then he/she will first pair his device to this module and after write a message in ‘BT Terminal’ mobile application.

After the message has been sent by user, bluetooth module will receive it and it sends this message to Arduino Board serially. As the ATmega 328P microcontroller receives this message, it will display the information on 16x2 LCD display.

Simultaneously, while displaying the message on LCD display, the microcontroller will also send this message serially to GSM Module (SIM 900). Sending the data through GSM module, we are sending this data to students/employees, etc, depending on the application.

If the message hasn't received from BT Terminal, the bluetooth module will continuously search for message to receive. And the message will remain displayed on the LCD display.

V. Application

- The proposed model is used in bus stations, railway stations, parks, etc. to display the messages wirelessly.
- This Project can also be used in colleges and organizations.
- The multi terminal is intended for simultaneous management of multiple accounts, such as WIFI and Bluetooth for which is mostly helpful for transmitting message to the display.

VI. Conclusion

An attempt has been made to make a practical model of ‘Design & Implementation of Wireless Notice board display based on arduino , Bluetooth and GSM Technology.’ As the technology is advancing every day the display board systems are moving from Normal hand writing display to digital display. Further to Wireless display units. This paper develops a photo type laboratory model wireless notice board system with GSM MODULE and BLUETOOTH MODULE connected to it, which displays the desired message of the user through an SMS in a most populated or crowded places. This proposed system has many upcoming applications in educational institutions and organizations, crime prevention, traffic management, railways, advertisements etc. Been user friendly and faster means of conveying information are major bolsters for this application. By using this proposed methodology we can enhance the security system and also make awareness of the emergency situations and avoid many danger.

Acknowledgement

It gives us great pleasure in presenting the paper on “Design & Implementation of Wireless Notice board display based on arduino , Bluetooth and GSM Technology”. We would like to take this opportunity to thank our internal guide of Electronics Engineering Department, JDCEM, Nagpur Prof. Shyam D.Bawankar for giving us all the help and guidance we needed. We are really grateful to them for their kind support. Their valuable suggestions were very helpful.

Reference

- [1]. Prof.Shyam D. Bawankar, Ashish .k Chutake ,Veshal S. Deshmukh, Parag S. lakde DESIGN AND IMPLEMENTATION OF MULTIPLE LED NOTICE BOARD BY USING ZIGBEE TECHNOLOGY. International Journal of Advances in Engineering & Scientific Research, Vol.2, Issue 2, Feb - 2015,
- [2]. The Data Sheet of ATmega 328p . <https://www.sparkfun.com/datasheets/Components/SMD/ATmega328.pdf>
- [3]. The data Sheet of Bluetooth HC-05
- [4]. <https://www.gme.cz/data/attachments/dsh.772-148.1.pdf>
- [5]. The Data Sheet of 16x2 LCD display
- [6]. <https://www.engineersgarage.com/electronic-components/16x2-lcd-module-datasheet>
- [7]. Modi Tejal Prakash, Kureshi Noshin Ayaz, Ostwal Pratiksha Sumtilal Digital Notice Board 2017 IJEDR | Volume 5, Issue 2 | ISSN: 2321-9939
- [8]. Muhammad Ali Mazidi, Janice G. Mazidi, Rolin D.McKinlay, The 8051 microcontroller and embedded systems using assembly and C, edition 01-Sep-2007,Pearson Education India.
- [9]. IoT based web controlled notice board.Divyashree M, Harinag Prasad S, Sandeep G T, Bhavya S N, Poornima S. International Research Journal of Engineering and Technology (IRJET) e-ISSN: 2395-0056 Volume: 05 Issue: 04 | Apr-2018 www.irjet.net p-ISSN: 2395-0072
- [10]. SMS And MMS Interworking In Mobile Networks Arnaud Henry- Labordère , Artech House mobile communications, 2004 - Technology & Engineering.
- [11]. GSM telecommunication standards, June 2000Second edition, European Telecommunications Standards Institute.
- [12]. P. S. Kumar, V. Priyanka, L. Surekha, and Y. H. Reddy, “Gsm based wireless electronic notice board display through arm7 and led,” International Journal of Advanced Technology and Innovative Research, vol. 8, no. 5, pp. 0864–0868, 2016.
- [13]. A. Meenachi, S. Kowsalya, and P. P. Kumar, “Wireless e-notice board using wi-fi and bluetooth technology,” Journal of Network Communications and Emerging Technologies (JNCET), vol. 6, no. 4, pp. 14–20, 2016.